

GENERAL NOTES:  
 REFERENTIE TEKENINGEN:

- 042207736-003210 Overzicht - Zelfsluitende kering 4m- Bak 3, 4 en 5 Rustende en Kerende stand
- 042207736-003211 Overzicht - Zelfsluitende kering 4m- Bak 3, 4 en 5 Details Itso's wand A & B
- 042207736-003212 Overzicht - Zelfsluitende kering 4m- Bak 3, 4 en 5 Itso's wand A & B
- 042207736-003213 Overzicht - Zelfsluitende kering 4m- Bak 5 - Draaipunten
- 042207736-003214 Overzicht - Zelfsluitende kering 4m - EPS drijver met A-frame
- 042207736-003215 Overzicht - Zelfsluitende kering 4m - Afsluitingen standaardklep
- 042207736-003216 Overzicht - Zelfsluitende kering 4m - Afsluitingen begin- en eindklep
- 042207736-003217 Overzicht - Zelfsluitende kering 4m - Afwerking en hekwerk bevestiging
- 042207736-003218 Overzicht - Zelfsluitende kering 4m - Onderhoudsstand
- 042207736-003219 Lasmontage - Zelfsluitende kering 4m - Standaard Klep
- 042207736-003220 Lasmontage - Zelfsluitende kering 4m - Begin- en Eindklep

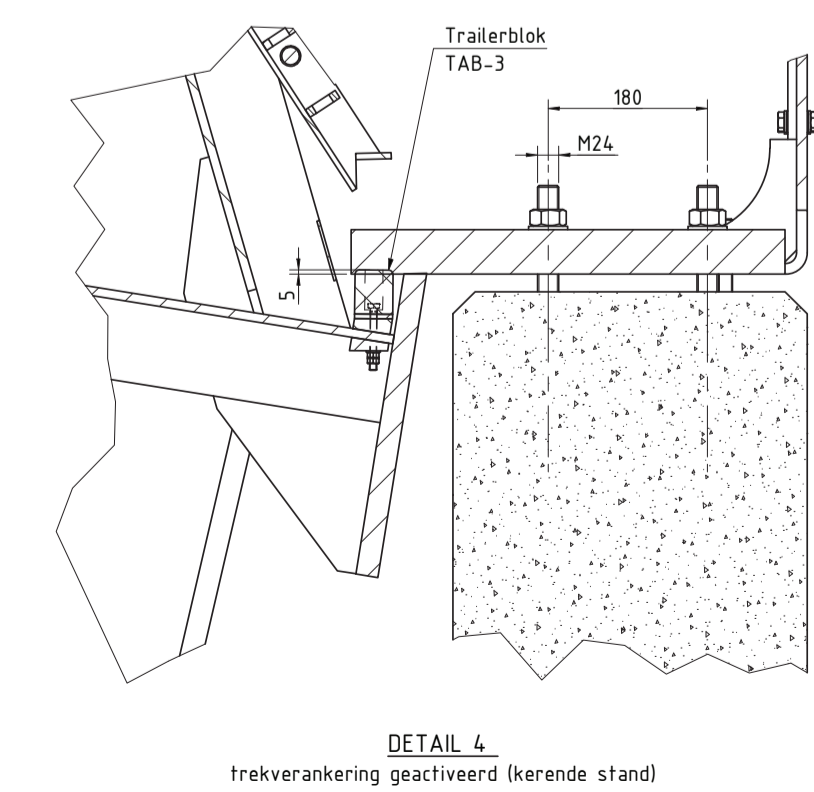

# TECHNISCH ONTWERP

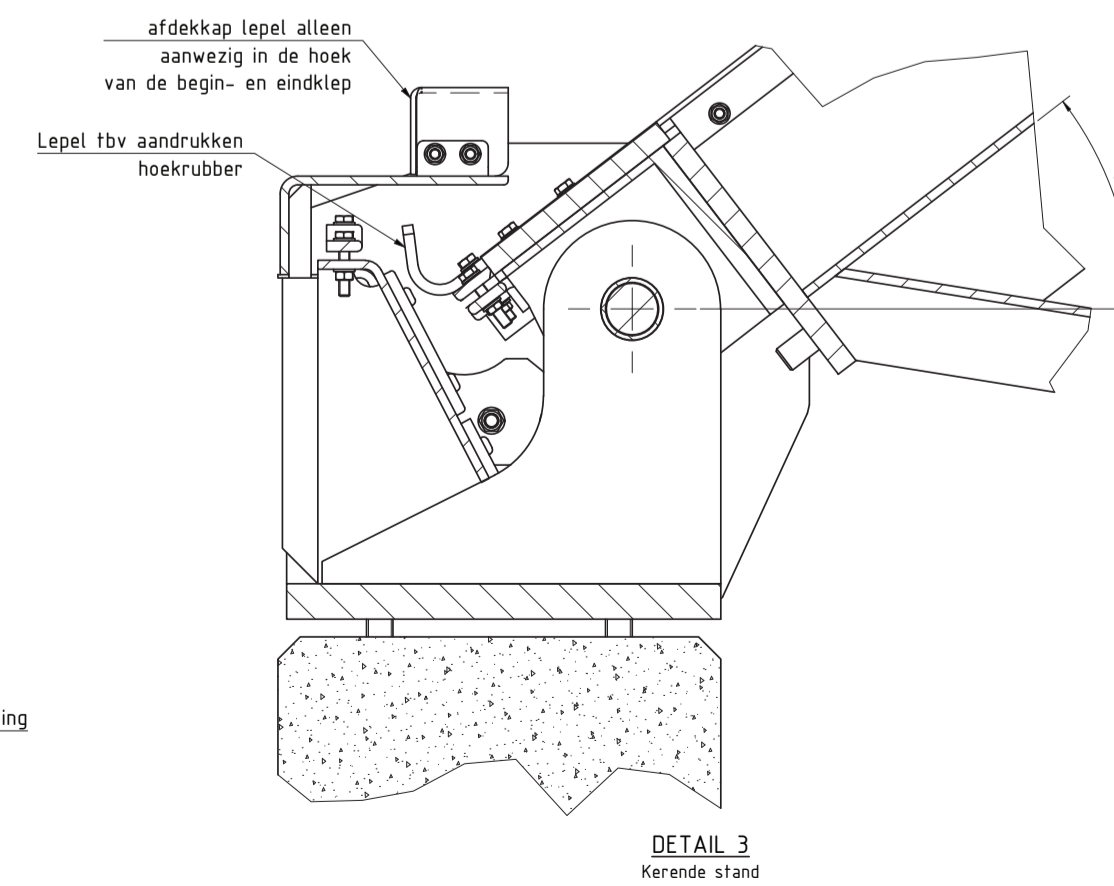
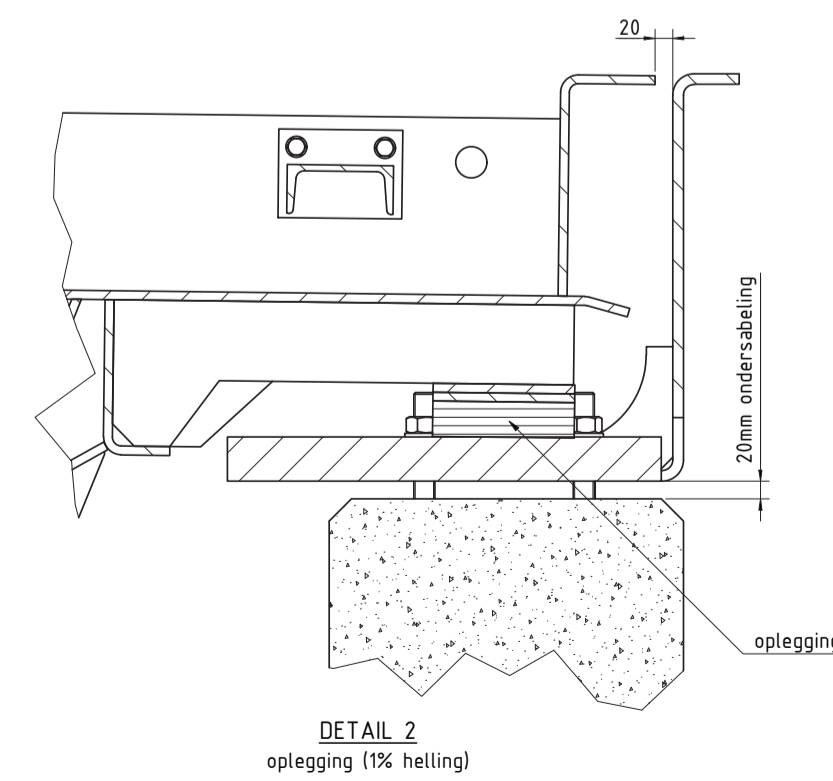
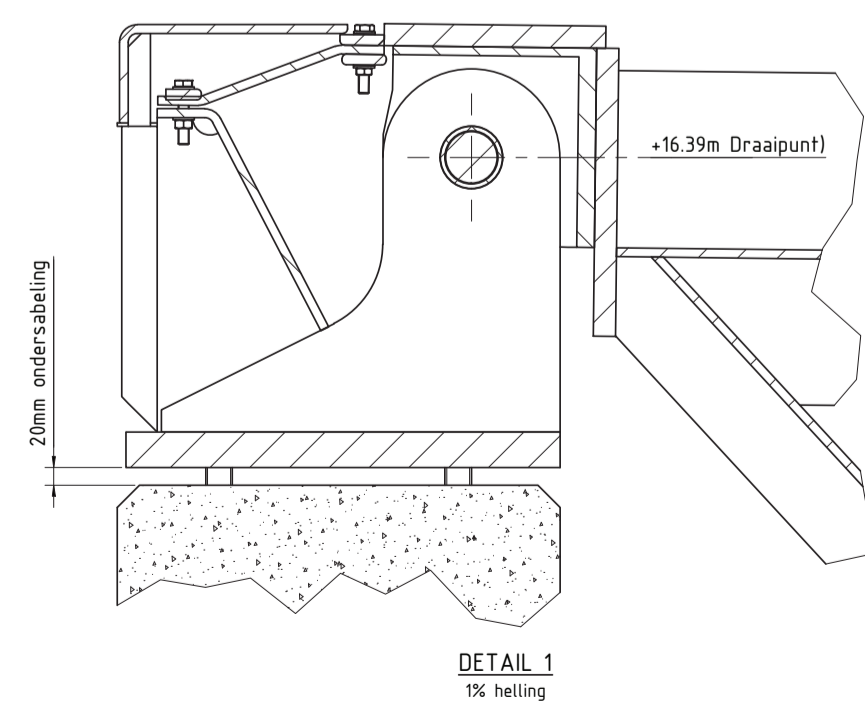
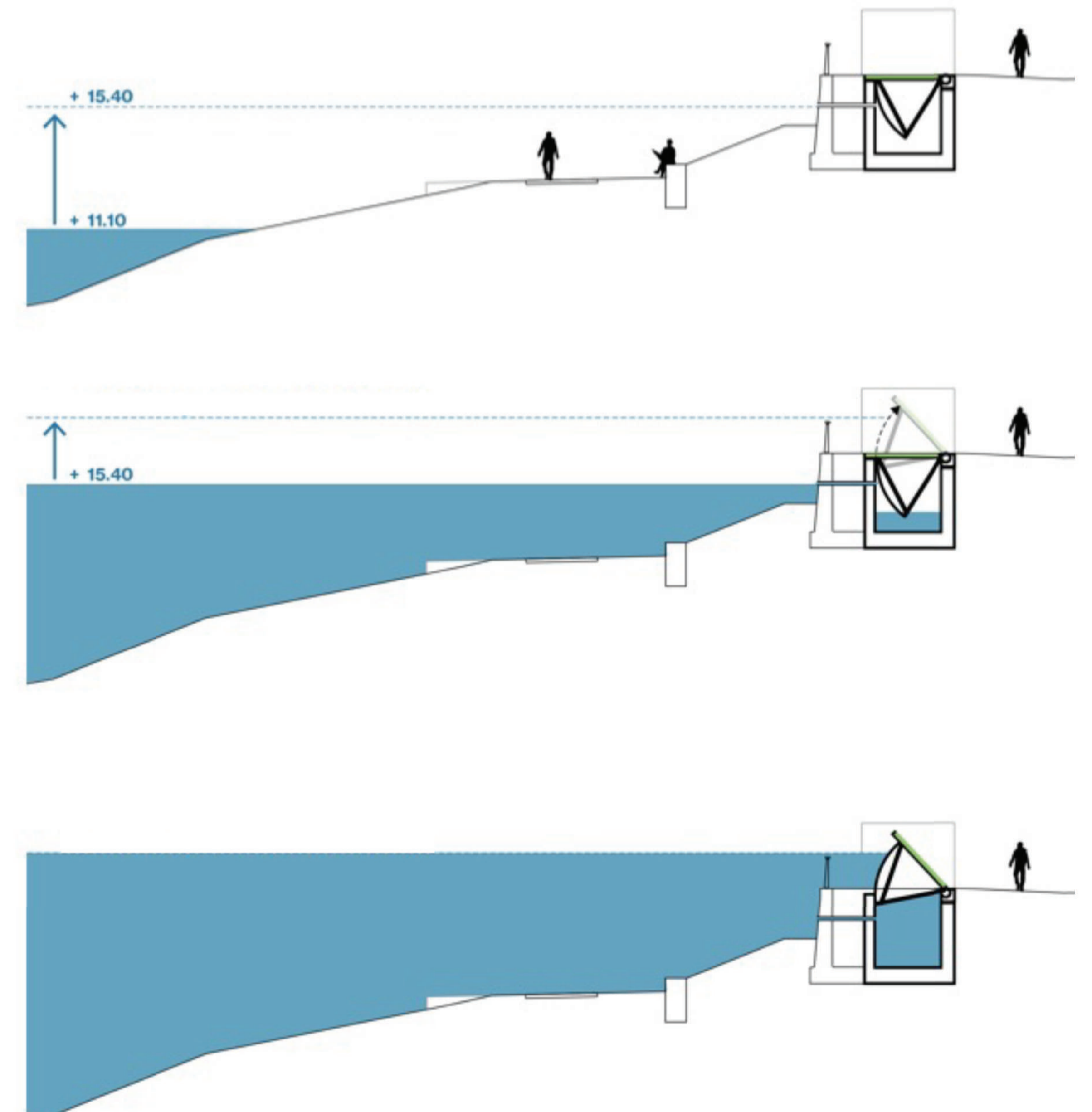
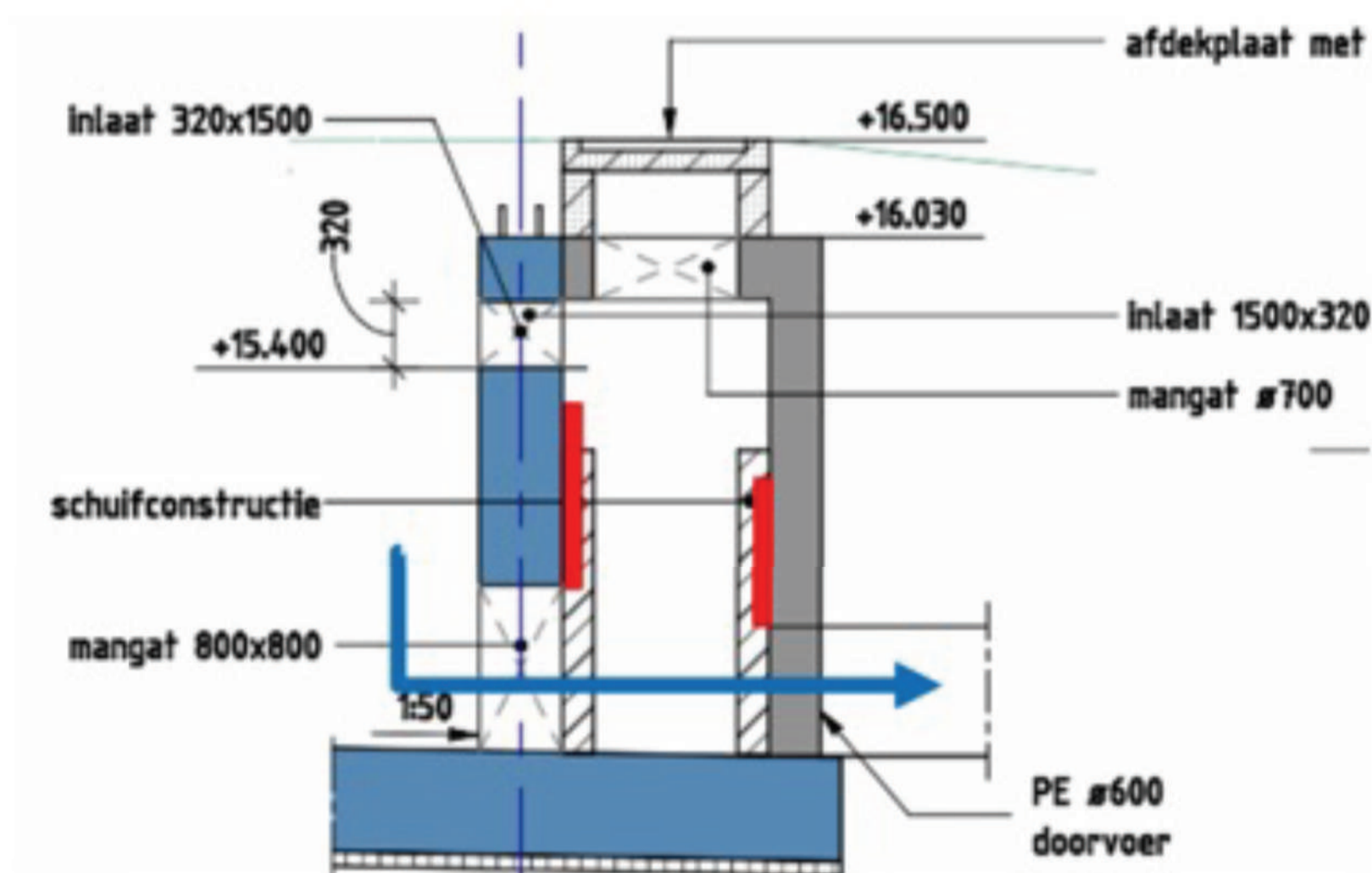
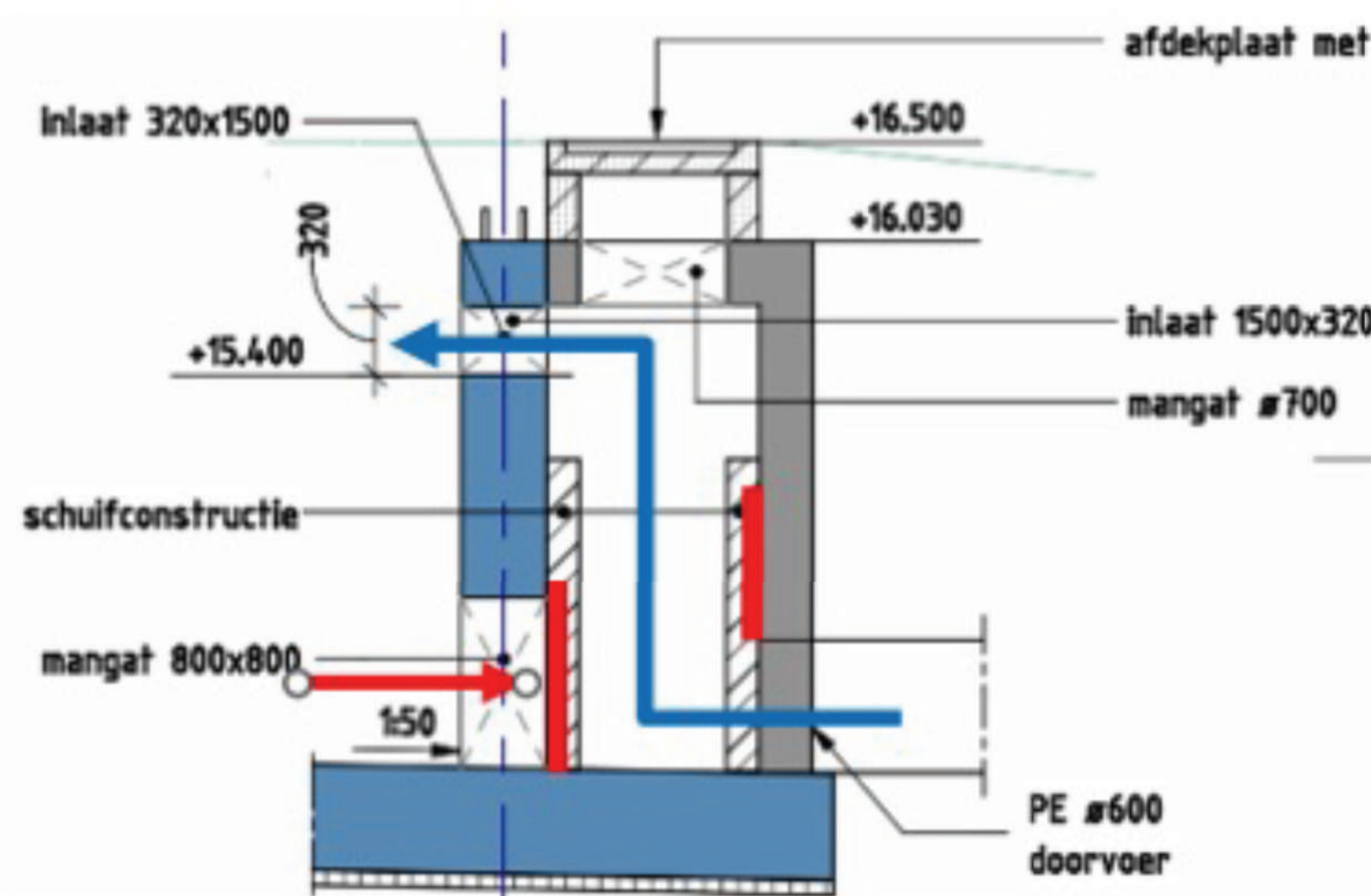
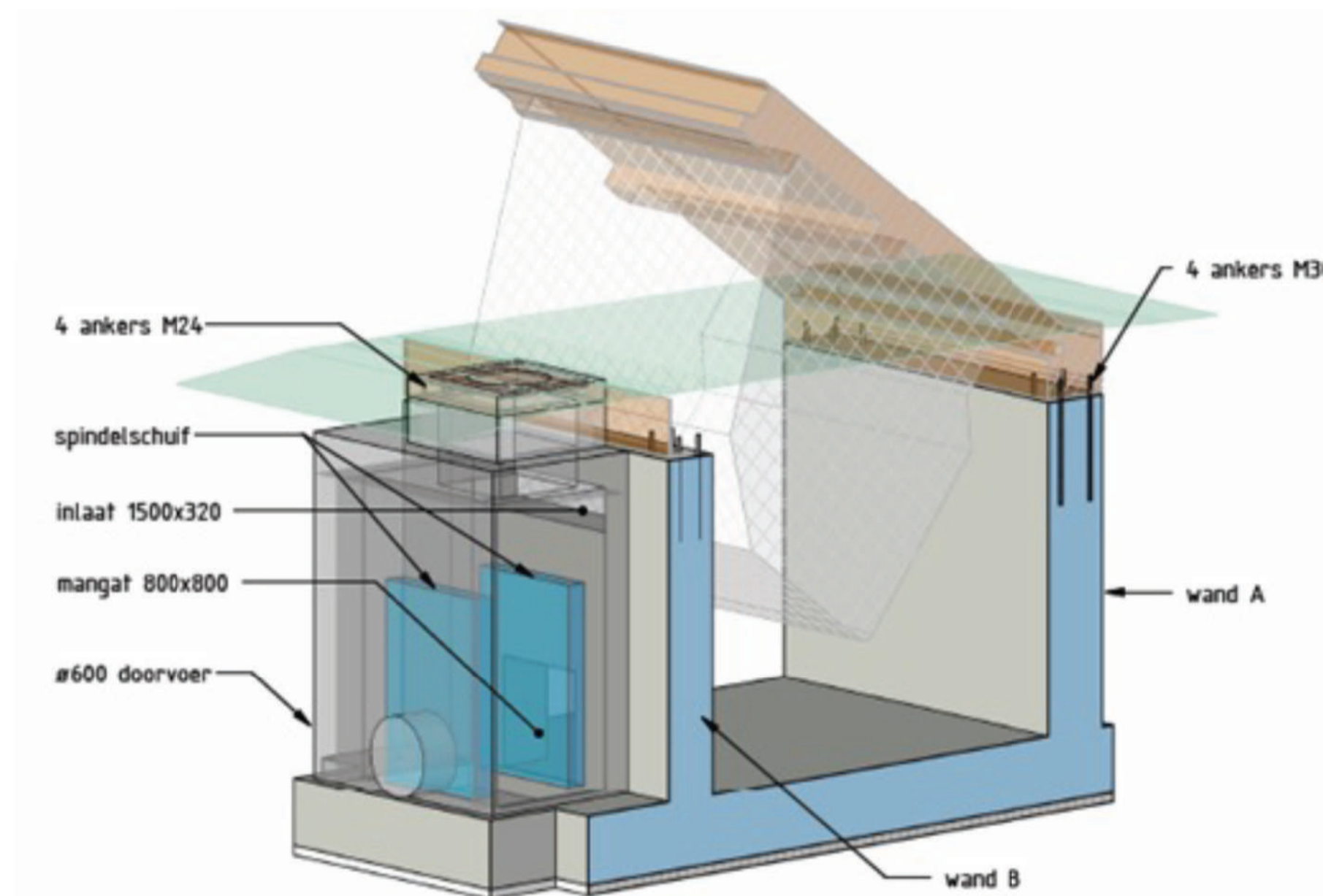
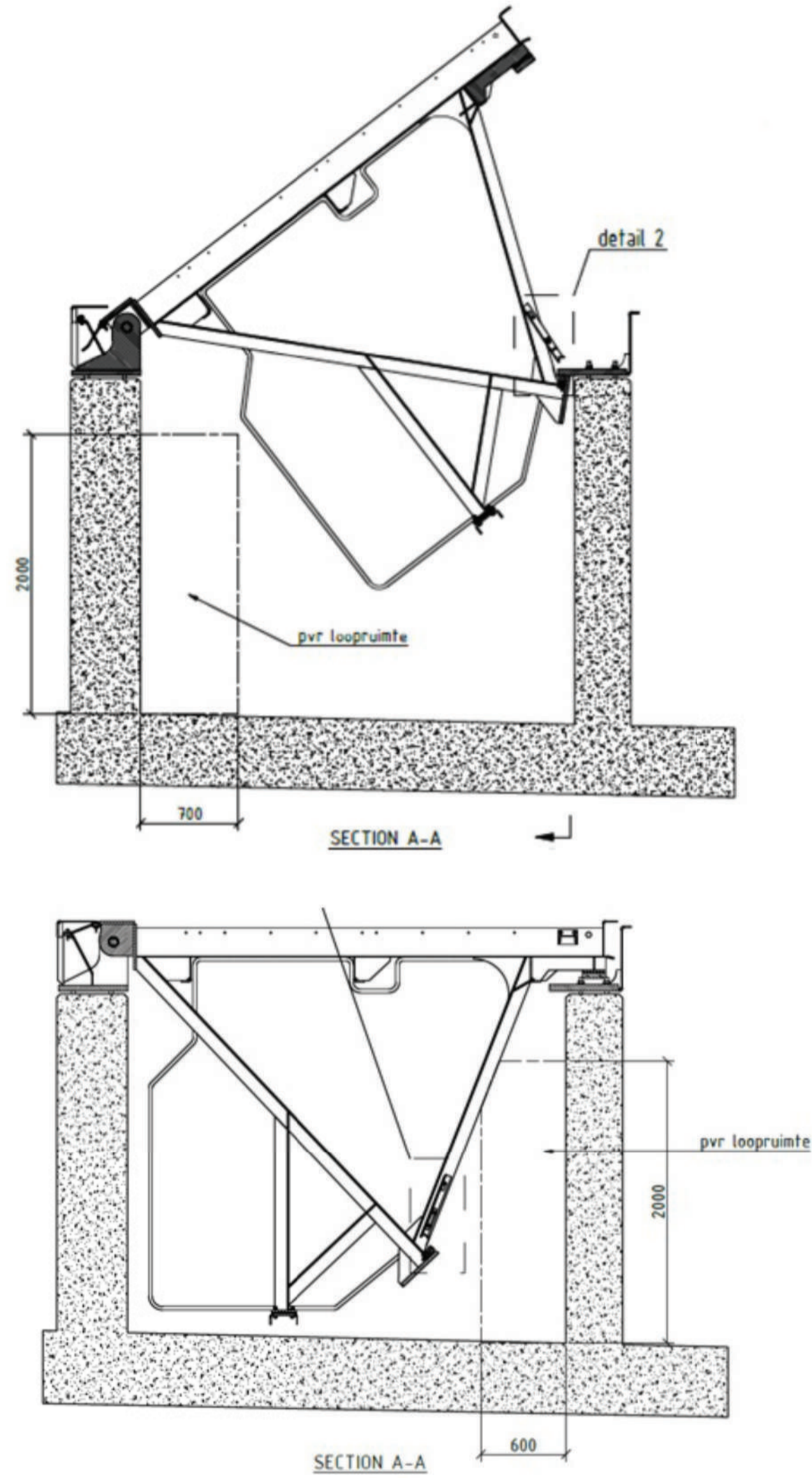

# TECHNISCH ONTWERP

